

- Built-in lock valve for positive rudder lock
- Integral relief valve for over-pressure protection
- 3/4" tapered stainless steel shaft
- Easy accessible lock valve and shaft seal for replacement
- Includes 90° adjustable fittings for 3/8" hose
- Corrosion proof composite housing
- For use with UC95-0BF, UC68-0BS and UC69-I cylinders only
- X74 square flange permits to install the UP20F pump in an intermediate dashboard position

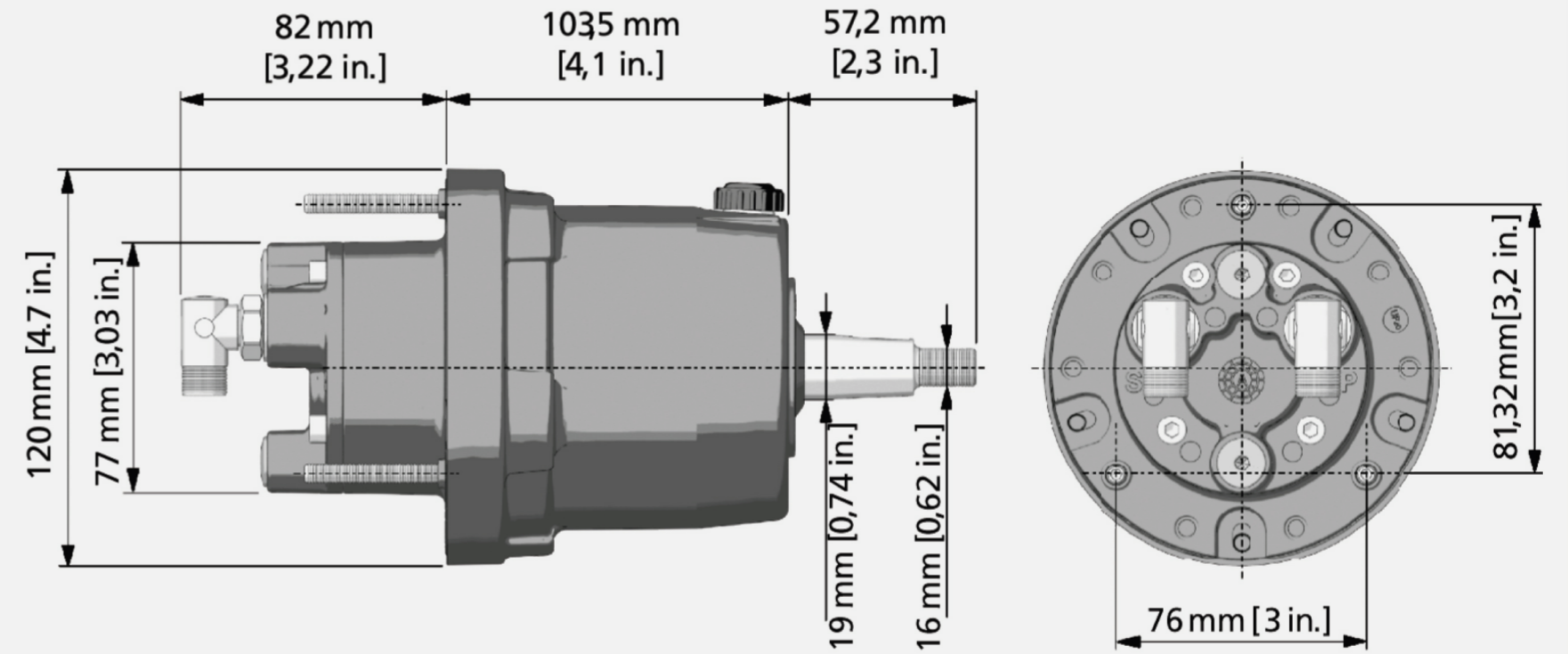

Mounting

FRONT MOUNT

Displacement/revolution

20 CC - 1.2 CU.IN

No. of pistons

5

Relief valve setting

70 BAR - 1000 PSI

Max. wheel diameter

508 MM (20")

Weight

3,6 KG (8 LBS)