

Electric Winch

(Permanent magnetic motor)

Assembly & Operating Instructions



INTRODUCTION

Thank you for purchasing a 2000lbs/2500lbs/3000lbs winch from our company. Please read and understand this Owner's Manual prior to installing and using your winch.

GENERAL DESCRIPTION

Each winch is equipped with a permanent magnet motor and is designed for intermittent duty general use. The winches not designed to be used in industrial or hoisting applications and the manufacturer goes not warrant it to be suitable for such use. Free spool Clutch is operated by a pull and turn knob which disengages the gearbox to allow the wire rope to be pulled out without using electric power. A tension plate reduces backlash and snarling when pulling out the wire rope.

GENERAL SAFETY INFORMATION

1. Never lift people or hoist loads over people. Do not lift items vertically. The winch was designed for horizontal use only.
2. **DO NOT OVERLOAD. FOR LOADS OVER 1000LBS/1250LBS/1500LBS, WE RECOMMEND THE USE OF THE OPTIONAL PULLEY BLOCK TO DOUBLE LINE THE WIRE ROPE(Figure 1)**
3. Do not attempt to prolonged pulls at heavy loads. The electric winch is designed for intermittent use only, and should not be used in a constant duty application. The duration of the pulling job should be kept as short as possible. If the Winch motor becomes very hot to the touch, stop the Winch and let it to cool down for several minutes. Never pull for more than one minute at or near the rated load.
4. **NEVER WINCH WITH LESS THAN 5 TURNS** of wire rope **AROUND THE WINCH DRUM** since the wire rope end fastener may **NOT** withstand full load.
5. **AVOID CONTINUOUS PULLS FROM EXTREME ANGLES** as this will cause the wire rope to pile up on one end of the drum (Figure 2) This can jam the wire rope in the winch, causing damage to the rope or the winch.
6. **BE SURE THE INPUT VOLTAGE BETWEEN THE TERMINALS OF MOTOR IS ALWAYS DC 12V IN ORDER TO REACH THE MAX RATED LINE PULL DURING THE OPERATION. AND PLEASE NOTE THAT IT ONLY CAN REACH THE MAX RATED LINE PULL BY FIRST LAYER OF CABLE AROUND THE DRUM WHEN PULLING THE LOADS.**

7. **NEVER HOOK THE WIRE ROPE BACK TO ITSELF** because you could damage the wire rope. Use a nylon sling.(Figure 3)
8. Be sure the winch mounted on the vehicle or other objective before operation.
9. When moving a load, slowly take up the wire rope slack until it becomes taut. Stop, recheck all winching connections. Be sure the hook is properly seated. If a nylon sling is used, check the attachment to the load.
10. It is a good idea to lay a heavy blanket or jacket over the wire rope near the hook end when pulling heavy loads(Figure 3). If a wire rope failure should occur, the cloth will act as a damper and help prevent the rope from whipping.
11. Do not move your vehicle to assist the winch in pulling the load. The combination of the winch and vehicle pulling together could overload the wire rope and the winch.
12. **NEVER WORK ON OR AROUND THE WINCH DRUM WHEN WINCH IS UNDER LOAD. (KEEP AWAY THE WINCH AT LEAST 1.5M DURING THE OPERATION)**
13. **DO NOT ACROSS OVER OR UNDER THE WIRE ROPE WHEN THE WINCH IS UNDER LOAD.**
14. When using your winch to move a load, place the vehicle transmission in neutral, set vehicle brake, and chock all wheels. The vehicle engine should be running during winch operation. If considerable winching is performed with the engine off, the battery may be too weak to restart the engine.
15. **NEVER RELEASE FREE SPOOL CLUTCH WHEN THERE IS A LOAD ON THE WINCH.**
16. After operation, please release the load. Do not allow the cable tight any more.
17. Always stand clear of wire rope, hook and winch.
18. **INSPECT WIRE ROPE AND EQUIPMENT FREQUENTLY. A FRAYED WIRE ROPE WITH BROKEN STRANDS SHOULD BE REPLACED IMMEDIATELY. USE ONLY FACTORY APPROVED SWITCHES, REMOTE CONTROLS AND ACCESSORIES. USE HEAVY LEATHER GLOVES WHEN HANDLING WIRE ROPE. DO NOT LET WIRE ROPE SLIDE THROUGH YOUR HANDS.**
19. Keep clear of winch, taut wire rope and hook when operation winch. Never put your finger through the hook. If your finger should become trapped in the hook, you could lose your finger. Always use the hand saver bar when guiding the wire rope in or out.
20. After operated the winch, re-spool the cable around the drum tightly.

21. **DO NOT OPERATE WINCH WHEN UNDER THE INFLUENCE OF DRUGS, ALCOHOL OR MEDICATION.** Always stay alert during the operation.
22. Use eye and ear protection. Always wear impact safety goggles. Wear a full face shield if you are producing metal filings or wood chips. Wear a dust mask or respirator when working around metal, wood, and chemical dusts and mists.
23. **DO NOT MACHINE OR WELD ANY PART OF THE WINCH.** Such alterations may weaken the structural integrity of the winch and could void your warranty.
24. Make some maintenance frequently for the winch.

INSTALLATION

Correct installation of your winch is required for proper operation.

1. Mount the winch on the vehicle or other object using Screw M8 x30, Lockwasher, Washer-Flat offered. Other similar screw can be instead.
WARNING: This winch must be mounted with the wire rope in the underwind direction. Improper mounting could damage your winch and void your warranty.
2. Route the two couple of lines from the switch to the motor and battery respectively. Connect the red line to the positive (+) terminal and the green (or black) line to the negative (-) terminal of the 12v battery. Connect the rest two lines to the terminal on the motor of the electric winch (Figure 4)
3. Check the direction of the drum turning.
Pull and turn the clutch knob to the "Off" position (drum can be turning free), pull out the cable from the drum then engaged the clutch by turning the knob to the "In" position. Push the "cable in" button on the handheld, if the cable is re-spooling then it is right way for connected. Otherwise please change the line connected the motor. And repeat the above mentioned operate.

OPERATION

1. Pull and turn the clutch knob to the "Off" position, so the drum can turn free by hand.
2. Grab the cable assembly hook and pull the cable to the desired length by

handsaver bar. Then attach to item being pulled.

WARNING: CHECK THAT THERE ARE AT LEAST FIVE TURNS OF WIRE ROPE LEFT ON THE DRUM BEFORE OPERATION.

3. Engaged the clutch by turning the clutch knob to the "In" position.

WARNING: CLUTCH MUST BE FULLY ENGAGED BEFORE WINCHING. NEVER ENGAGE CLUTCH KNOB WHILE DRUM IS TURNING. THE CLUTCH KNOB HAS BEEN ADJUSTED AND PERMANENTLY LOCKED IN PLACE WITH A THREAD LOCKING COMPOUND AT THE FACTORY. DO NOT ATTEMPT TO RE-ADJUST THE KNOB.

4. Push and hold the "Cable In" button on the handheld and the cable was re-spooled.

Push and hold the "Cable Out" button to reverse directions. Wait until the motor stops before reversing directions.

5. Re-spooling cable after finished operation.

MAINTENANCE

1. Periodically check tightness of mounting bolts and electrical connections. Remove all the dirt or corrosion that may have accumulated on the electrical connections.

2. Do not attempt to disassemble the gearbox. Disassembly will void warranty. Repairs should be done manufacturer or authorized repaired center.

3. The gearbox having been lubricated using high temperature lithium grease at the factory.
No internal lubrication is required.

REPLACE THE WIRE ROPE

1. Engaged the clutch by turning the clutch knob to the "In" position.
2. When inserting the wire rope into the drum, insert it into the correct end of the hole provided.(Figure 5). Tighten the set screw securely.
3. Operate the winch and re-spool the wire rope around the drum.

CAUTION:

ALWAYS REPLACE DAMAGED WIRE ROPE WITH MANUFACTURERS IDENTICAL REPLACEMENT PART.

TROUBLESHOOTING

SYMPTOM	POSSIBLE CAUSE	SUGGESTED ACTION
Motor will not operate or runs in one direction only	-Switch inoperative -Broken wires or bad connection -Defective motor	-Replace switch -check for poor connections -Replace or repair motor
Motor runs but drum does not turn	-Clutch not engaged	-Engage clutch
Motor runs but with insufficient power or line speed	-Weak battery -Defective motor	-Recharge or replace battery. -Check battery terminals for corrosion. Clean as required -Check and clean connections -Repair or replace motor
Motor overheating	-Winch running time too long -Defective motor	-Allow winch to cool down periodically -Repair or replace motor

Winch Parts List (2000lbs)

Item #	Part #	Qty	Description
1	200100	1	Motor
2	200200	1	Stationary Gear Housing Assembly
3	200300	1	T-Series Carrier Assembly
4	200400	1	T-Series Rotator Gear
5	200500	1	Drum Support Plate
6	200600	4	Pan Head Screw M4X12
7	200700	1	Drum Support Bushing
8	200800	1	Clutch Assembly
9	200900	1	Spring
10	200001	1	Durm Assembly
11	200002	1	Screw M5X5
12	200003	1	T-Series Bushing
13	200004	1	Thick Flat Washer
14	200005	2	Hex Flange Nut M5
15	200006	1	T-Series Baseplate Assembly
16	200007	1	Tension Plate
17	200008	1	T-Series F/W Knob Assembly
18	200009	1	Elastic Pin 2.5X14
19	200010	2	Hex Skt FH Screw M6x16
20	200011	2	Screw
21	200012	2	Screw M8x30
22	200013	2	Washer-Flat ϕ 8
23	200014	2	Lock Washer ϕ 8
24	200015	2	Nut M8
25	200016	1	Red strap
26	200017	1	Switch Assembly
27	200018	1	Cable Assembly
28	200019	1	Tie Bar (2000lbs not need it)
29	200021	1	Control Box
30	200022	2	Relay
31	200023	1	Wire
32	200024	1	Wireless Switch

When ordering parts from this list, make sure to indicate that the part number was from the Winch Parts List.

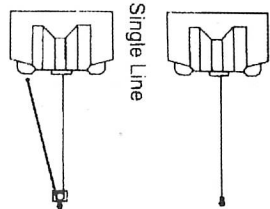

Figure 1

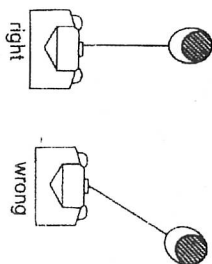

Figure 2

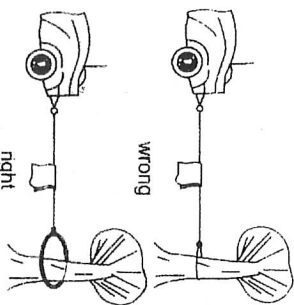

Figure 3

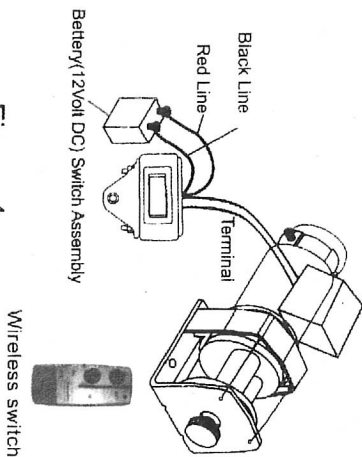

Figure 4

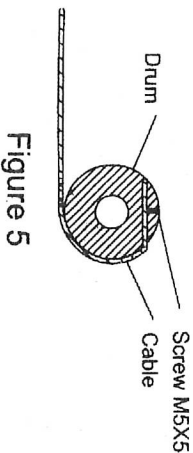
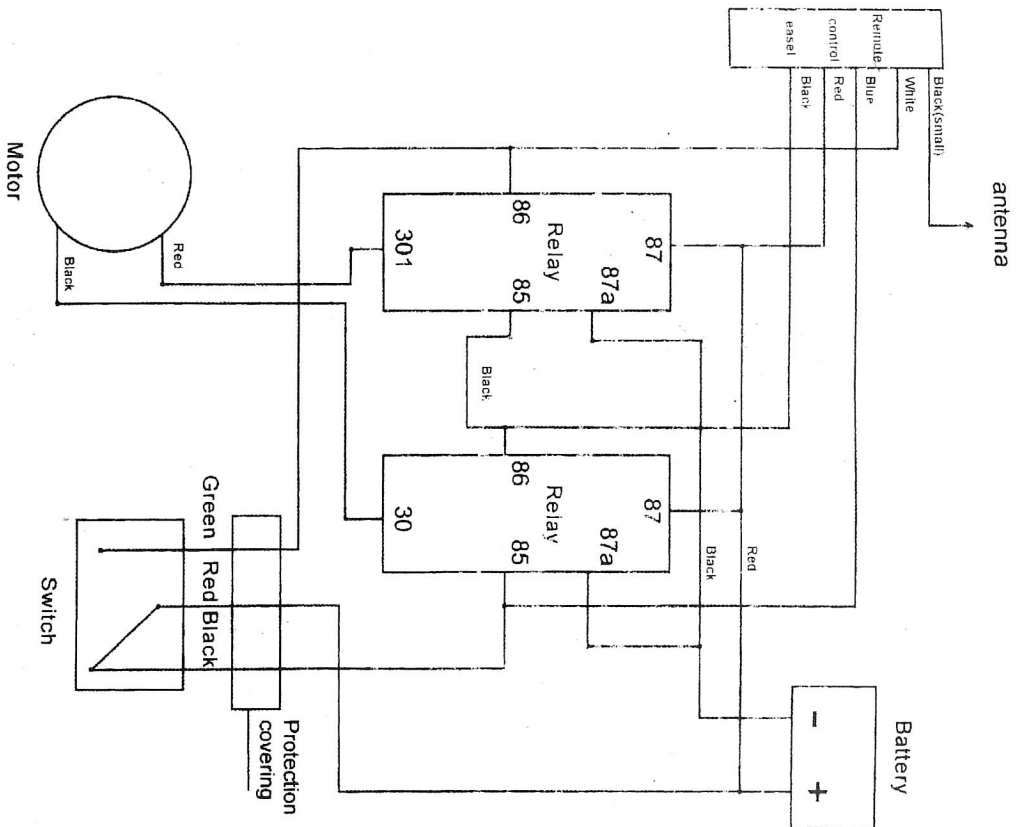
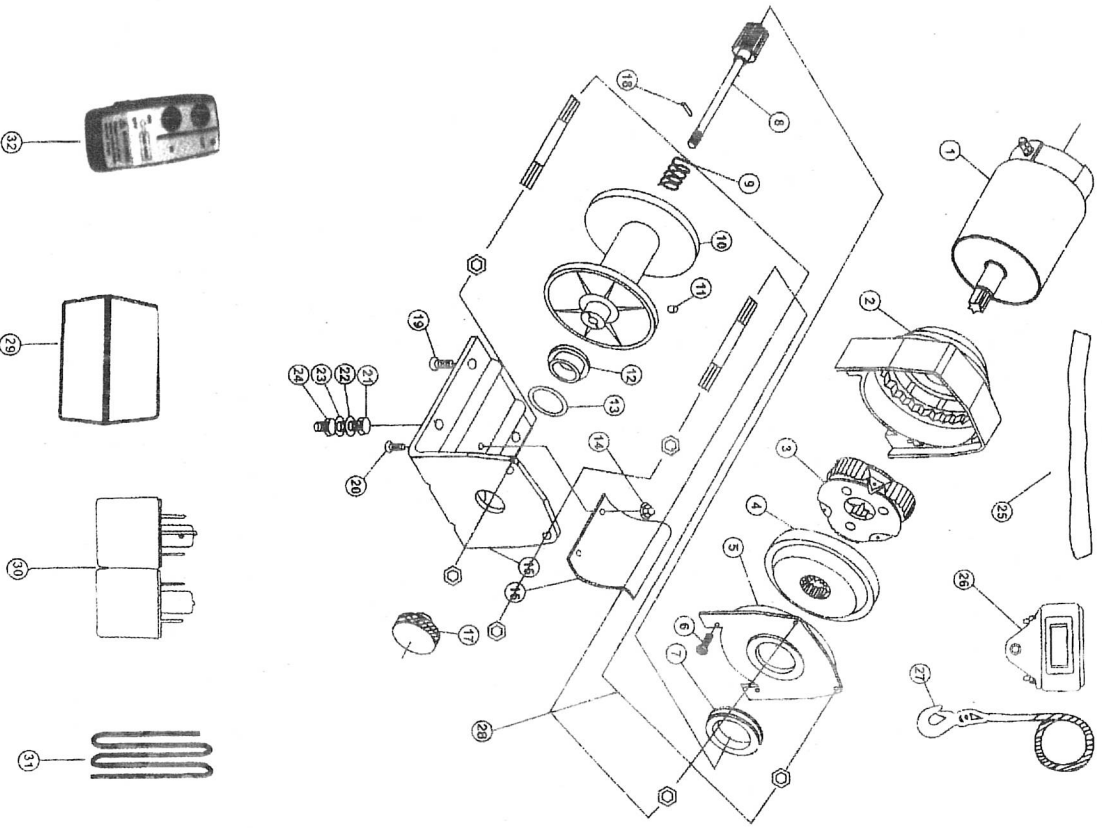

Figure 5

Winch Assembly Drawing



2000LBS

Performance Specifications

Single line rated pull

2000lbs(906kgs)

Gear reduction ratio

153:1

Motor

Permanent magnet DC 12V motor
with 0.85 hp output

Overall dimensions

7.3" (L)x4.1" (W)x4.1" (H)
285(L)x105(W)x105(H)mm

Drum size

∅ 1.24(D)x2.88" (L)
∅ 31.5(D)x73(L)mm

Cable length

49ft(L) of ∅ 5/32" Cable
15m(L) of ∅ 4mm Cable

Weight

12lbs
5.5Kgs

Line speed and Motor current(First layer)

Line Pull	Lbs	500	1000	1500	2000	
	Kgs	0	227	454	680	907
Line speed	FPM	10.5	9.2	7.2	5.2	2.9
	MPM	3.2	2.8	2.2	1.6	0.9
Motor current	Amps	8	30	60	90	120

Line pull and Cable capacity

Layer of cable	1	2	3	4	5	6	
	Rated line pull perlayer	Lbs 2000	1630	1380	1190	1050	940
	Kgs 907	740	620	540	470	420	
Cable capacity perlayer	Ft.	6.5	14	23.5	35	47	50
	M	2.0	4.3	7.2	10.6	14.4	15.2

2500LBS

Performance Specifications

Single line rated pull

2500lbs(1133kgs)

Gear reduction ratio

153:1

Motor

Permanent magnet DC 12V motor
with 1 hp output

Overall dimensions

7.3" (L)x4.1" (W)x4.1" (H)
300(L)x105(W)x105(H)mm

Drum size

∅ 1.24(D)x2.88" (L)
∅ 31.5(D)x73(L)mm

Cable length

39.3ft(L) of ∅ 3/16" Cable
12m(L) of ∅ 4.8mm Cable

Weight

14.3lbs
6.5Kgs

Line speed and Motor current(First layer)

Line Pull	Lbs	500	1500	2500	
	Kgs	0	227	680	1133
Line speed	FPM	10.5	9.2	5.9	3.2
	MPM	3.2	2.8	1.8	1.0
Motor current	Amps	10	25	60	120

Line pull and Cable capacity

Layer of cable	1	2	3	4	5	
	Rated line pull perlayer	Lbs 2500	1980	1640	1400	1220
	Kgs 1133	985	740	630	550	
Cable capacity perlayer	Ft.	5.5	12.4	20.9	30.7	39.3
	M	1.7	3.8	6.4	9.4	12

3000LBS

Performance Specifications

Single line rated pull

3000lbs(1361kgs)

Gear reduction ratio

153:1

Motor

Permanent magnet DC12V motor
with 1 hp output

Overall dimensions

7.3" (L)x4.1" (W)x4.1" (H)
300(L)x105(W)x105(H)mm

Drum size

∅ 1.24(D)x2.88" (L)
∅ 31.5(D)x73(L)mm

Cable length

30.1ft(L) of ∅ 11/51" Cable
9.2m(L) of ∅ 5.5mm Cable
14.3Lbs
6.5Kgs

Weight

Line speed and Motor current(first layer)

Line Pull	Lbs	0	1000	2000	3000
	Kgs	0	454	906	1361
Line speed	FPM	10.5	7.5	4.2	2.3
	MPM	3.2	2.3	1.3	0.7
Motor current	Amps	10	40	90	145

Line pull and Cable capacity

Layer of cable	1	2	3	4	5	
	Rated line pull perlayer	Lbs	3000	2250	1890	1590
Kgs		1361	1022	859	722	622
Cable capacity perlayer	Ft.	4.9	11.5	19.3	28.5	30.1
	M	1.5	3.5	5.9	8.7	9.2