



THRUSTME

THE KICKER

Møt «Kicker» - som tar elektriske påhengsmotorer til et nytt nivå.
Kicker er den mest kompakte elektriske påhengsmotoren på markedet med internt batteri.
Totalvekten er på bare 4,4 kg inkludert det interne batteriet.

Kicker kommer med alt du trenger for å bruke den på båten din, inkludert en bæreseske for enkel og sikker transport.

Produktet er designet og utviklet i Norge, teamet har erfaring fra Subsea industri og luftfartsindustri, dette gir produktet en enestående kvalitet som er designet for langvarig bruk.



Designed and developed in Norway



THRUSTME

KICKER



THRUSTME
KICKER

INSTRUCTION MANUAL



thrustme.no

- Totalvekt 4,4 kilo
- Vanntett
- Trådløs fjernkontroll
- Fungerer for båter på opptil 20 fot
- Bæreveske for transport og sikker lagring inkludert

INCLUDED IN THE BOX



CRUISER remote X1



Magnetic kill switch X1



Wrist band for remote X1



CRUISER charger 230V X1



KICKER motor X1



Designed and developed in Norway



THRUSTME

KICKER

Display som viser batteristatus, trinn og retning.

Ladeplugg / ekstern batteritilkobling

Docking for trådløs fjernkontroll



Magnetisk nød stopp



Designed and developed in Norway



THRUSTME

KICKER

Display egenskaper

- Fjernkontroll av/på
- Thrustmeter
- Batteristatus internt batteri
- Batteristatus eksternt batteri
- Fjernkontroll med induksjons ladning



Fjernkontroll egenskaper

- Vibrasjon
- vanntett
- Indikator lys





THRUSTME

KICKER



Justeringskrue:
For høydejustering for å passe nesten alle båter.
Friksjonskrue for å feste motoren.

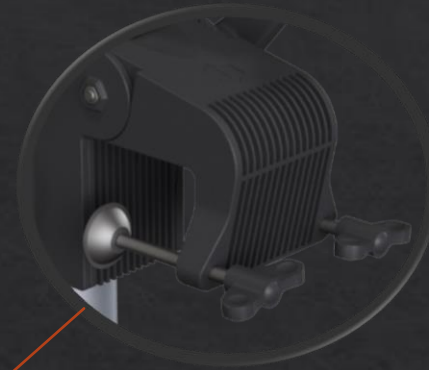
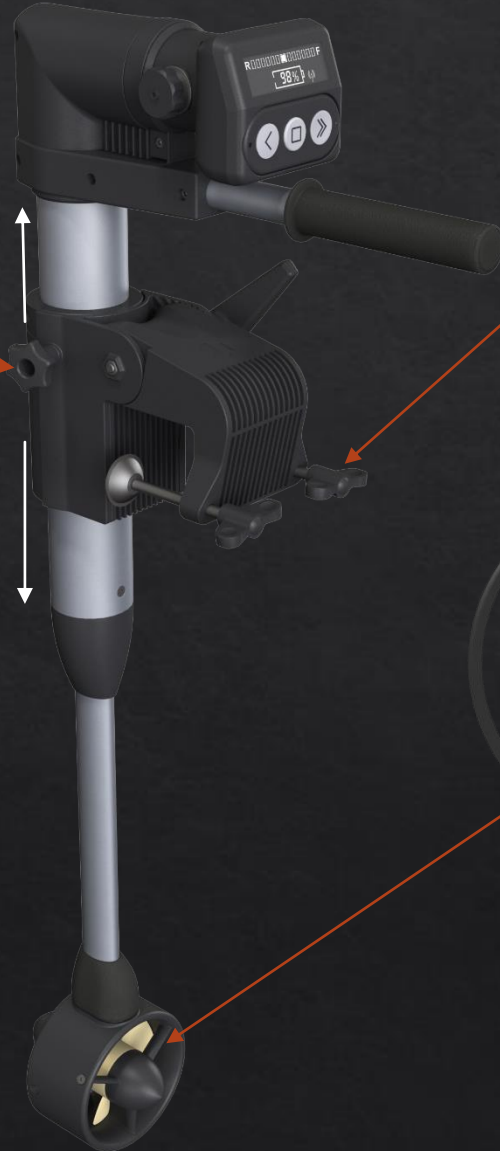

Akterspeil feste:

- Enkelt feste som passer de fleste båter med akterspeil.

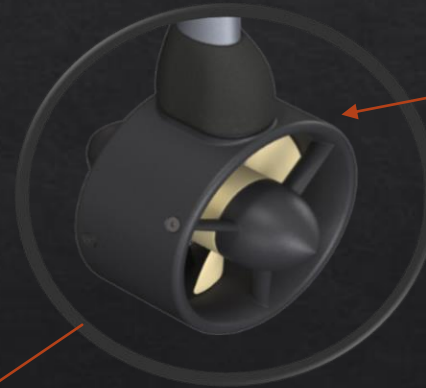

Thruster "huset"

- Beskytter propellen
- Øker effektiviteten

Propeller / Thruster:

Liten, men sterk thruster for sikker og langvarig opplevelse.
Ingen behov for vedlikehold - skyl i ferskvann etter bruk.
Den kraftigste thrusteren på markedet sammenlignet med størrelsen.



Designed and developed in Norway



THRUSTME

KICKER

Størrelse :



90 cm

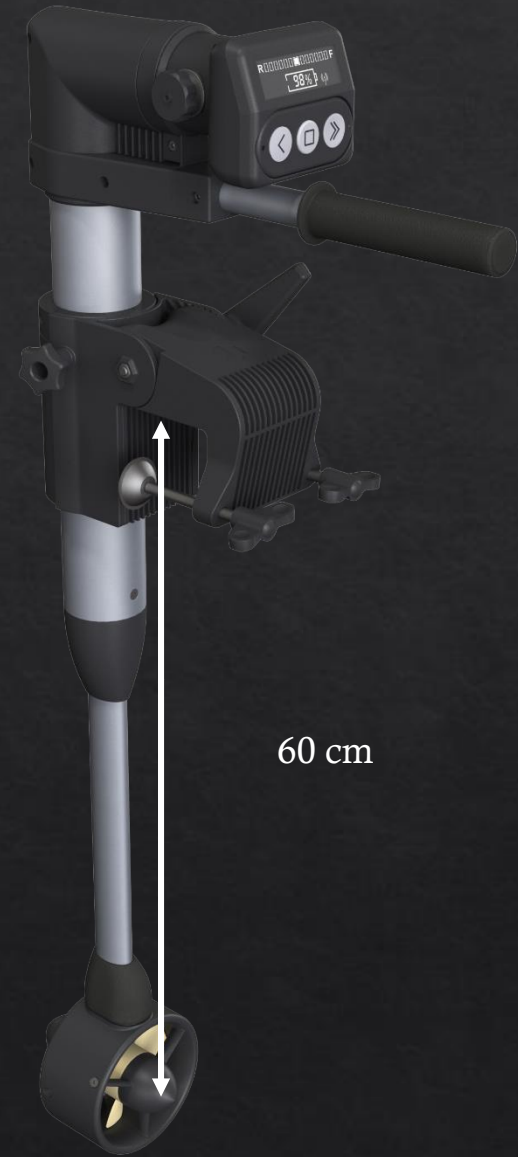

60 cm



Designed and developed in Norway



THRUSTME

KICKER

Håndtak:

- Mykt gripehåndtak
- Kan fjernes for enkel transport
- Justerbart teleskophåndtak



Tilt og låsehendel

- Hendelen settes i åpen posisjon ved justring av vinkelen
- Enkel i bruk

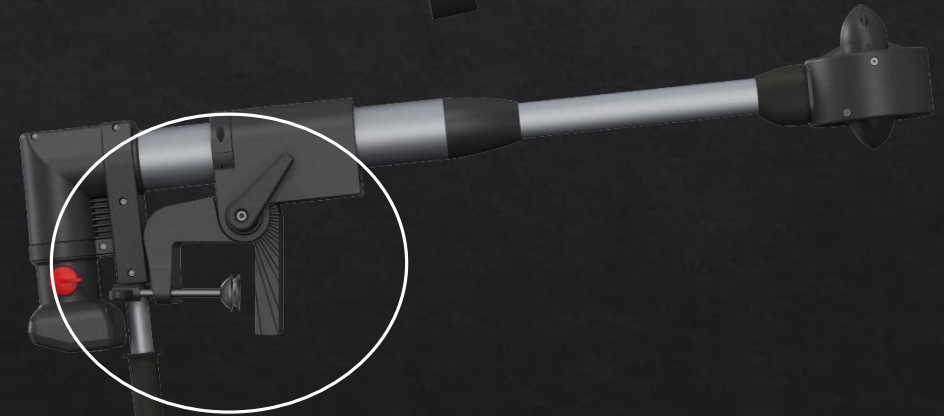

Designed and developed in Norway



THRUSTME

KICKER

Internt batteri

- 18,5 V (ladekraft 21V)
- 14000 mAh
- Smart batteri med beskyttelse
- Beskyttelse mot overutladning, beskyttelse mot kortslutning.
- Temperatur beskyttelse
- Innebygd sikkring for sikker bruk
- RHOS godkjent
- UN 38,3 Godkjent (Transport godkjennelse)
- 1000 ladesykluser
- Fullt ladet på 4 timer medfølgende original lader
- Fullt ladet på bare 1-time ved bruk av hurtiglader (ekstra utstyr)



Designed and developed in Norway



THRUSTME

KICKER

FUNKSJONER

- Kan monteres på hvilken som helst båt opp til 20 fot på under 1 minutt.
- Alt i en enhet med innebygd batteri.
- Kan flyttes mellom fartøyer på få minutter.
- Lett vekt, bare 4,4 kg.
- Enkel oppbevaring som tar liten plass.
- Lang brukstid sammenlignet med størrelse og vekt.
- Ladere tilgjengelig :
 - 220V Original lader
 - 220v Hurtig lader
 - 12V Lader til bil/båt



Designed and developed in Norway



THRUSTME

KICKER

Vekt: 4,4 kg

Motor: Børsteløs motor

Skyvekraft: 16 kg Fremover / 12 kg Revers

Batteri: Intelligent Li-io 18,5V 14Ah

Fjernkontroll trådløs Snap On /OFF

Trådløs lader for fjernkontrollen

Nødstop: Magnetisk

Farge: Svart / grå

Ladetid: ~ 4 timer / 230 V lader inkludert

Kan benyttes i ferskvann og saltvann

