

CORTEX

VHF | AIS | MONITOR

H1 QUICK-START GUIDE



vesper

Getting to know the handset

- 1 Distress
- 2 Speaker
- 3 Lanyard Loop
- 4 Volume Up
- 5 Volume Down
- 6 Power
- 7 Push to Talk PTT
- 8 Menu
- 9 Click-wheel
- 10 Back
- 11 VHF (VHF Radio key)
- 12 Power light (Red)
Also ambient light sensor for auto dimming.
- 13 Touchscreen
- 14 Microphone
- 15 Call* (Hold down for DSC menu shortcut)
Otherwise use when a target is selected to initiate a call.
- 16 Enter
- 17 Channel 16
- 18 Man Overboard (MOB)

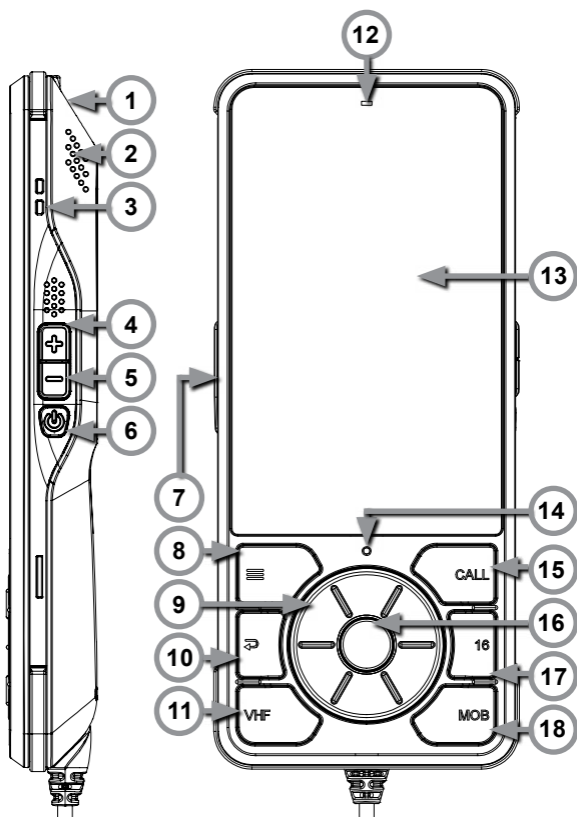

To connect a handset to an M1

- 1 Turn Cortex M1 ON
Switch the vessel's batteries ON to power the M1.
- 2 Turn the handset ON
Press and hold the Power button for 2 seconds.
- 3 Select WiFi from the Status Bar



- 4 From the list of available WiFi, identify and select the M1 WiFi SSID.

Note - The WiFi SSID is identified by the M1 serial number eg: CORTEX-95211616

Note - The Cortex V1 package (M1+H1) ships with the handset pre-configured to the M1.

- 5 Key the WiFi Password found on the label supplied with the M1.
- 6 Select CONNECT to save.
Text '*connected*' will confirm the connection.
- 7 Select the Back key to close the WiFi status.

Questions and FAQ's

Visit www.vespermarine.com/faqs for answers to frequently asked questions, technical support, downloads, local dealer contacts and more.

Register Your Cortex

Vesper Marine releases product updates from time to time. These updates often add new features. Please note the images in this guide might differ to what you see on your product. To be notified when an update is available please register your Cortex at www.vespermarine.com/register.

Main Menu

Select the Main Menu button (☰) on the keypad or the Main Menu icon (☰) on the left of the Status Bar.

Standard functions:

- > Plotter (Plotter view of AIS targets)
- > Directory (AIS targets and manual DSC contacts)
- > VHF (VHF Radio)
- > Instruments (GPS and NMEA data)

Situational functions:

- > Anchor watch (Monitor the vessel at anchor)
- > Collision avoidance (Assess and manage a potential collision scenario)
- > MOB (Man Overboard monitoring)

The Configuration Menu is used for initial setup and system monitoring including AIS programming, network settings and sensor setup.

- > Main Menu (☰) > touch on the wrench icon (🔧) to open the Configuration Menu.



Status Bar

The Status Bar is available from any screen for swift access to the important information.

1 Menu

2 VHF Channel, RX Status, TX Power (H or L)

3 Transponder status (example pictured)

Transponder receive only mode (Stealth mode) is controlled from within this menu.

4 WiFi status (Select, connect and confirm M1 WiFi)

5 Battery status (H1P only)

The Power light (above touchscreen) indicates:

Solid	Idle mode / Charging
Pulsing	Discharging off cradle
Flashing	Discharging on cradle

6 GPS status

Satellite view and GPS settings

7 Alarm status





VHF

Loud, clear and easy to operate VHF radio engineered for the harsh marine environment.

- | | |
|---|---|
| 1 Your Vessel Details | 8 Selected Channel
(Swipe to change or use click-wheel) |
| 2 Transmission Power | 9 VHF Mute
(alarms still active) |
| 3 Push to Talk | 10 Dual Watch |
| 4 Last Channel | 11 VHF Settings |
| 5 Channel Presets | 12 Call (Initiate DSC Call) |
| 6 Change Channel
(Or via touchscreen) | 13 Channel 16 |
| 7 VHF (VHF Radio key) | |



To make a VHF call

1 Select VHF

Select via a keypad button (VHF) or the Main Menu.

2 Select the appropriate channel

You can also press the PTT key from any screen if the required channel is already selected to bypass steps 1 and 2.

3 Verify the channel is clear

You cannot obstruct the communications of other channel users due to Federal Communications Commission (FCC) and international guidelines.

4 Press the Push To Talk (PTT) key

'Transmitting' is displayed.

5 Speak into the handset

6 Release the PTT key



To send an individual DSC call

Note - DSC can also be swiftly accessed from the Plotter, Directory and Situational screens.
The CALL button can also be used, hold it down to access the DSC menu.

> Select the target > CALL the target



Fig. 1

Fig. 2

Fig. 3

- 1 Select the Plotter or Directory screen
- 2 Select an AIS target (Fig.1 & 2)
- 3 Select the Call icon (Fig.3)
- 4 Follow the on screen instructions to confirm or change the target vessel MMSI and channel
- 5 Select the CALL icon when ready

Once you activate CALL, the DSC Individual Call screen monitors the status of your DSC call.

- > If your Individual DSC call is unanswered you may **RESEND**.
- > If your Individual DSC call is answered you may **CONTINUE CALL** or select **END CALL**.
- > **END CALL** ends the DSC call and opens the VHF screen on the requested channel.



Instruments

The M1 receives data (PGNs) from instruments on the NMEA network.

1 Instrument Fields

Each field is customizable from available sensors on board. Options include:

- Depth
- COG
- SOG
- Heading
- Speed
- Apparent Wind
- True Wind
- Ground Wind
- Water temp
- UTC
- Position

2 Field Lock

Select the icon to lock and unlock each instrument view. Swipe through available instruments.

3 Instrument Settings

Select an instrument layout:





Plotter

View AIS targets with smartAIS filtering (adjustable).
Select any vessel to make a direct DSC call.

- 1 Number of Targets**
- 2 Class A Vessel**
- 3 Target Speed**
- 4 Class B Vessel**
- 5 Your Vessel**
- 6 Vector Line**
Position a target will be in 10 minutes.
- 7 Range Markers**
- 8 Plotter Settings**
Orientation, Declutter, Collision Profile, Alarm settings

	<5 Knots
	5-9 Knots
	10-14 Knots
	15-19 Knots
	<20 Knots
	Class A
	Class A Towing
	Class B Power
	Class B Sail

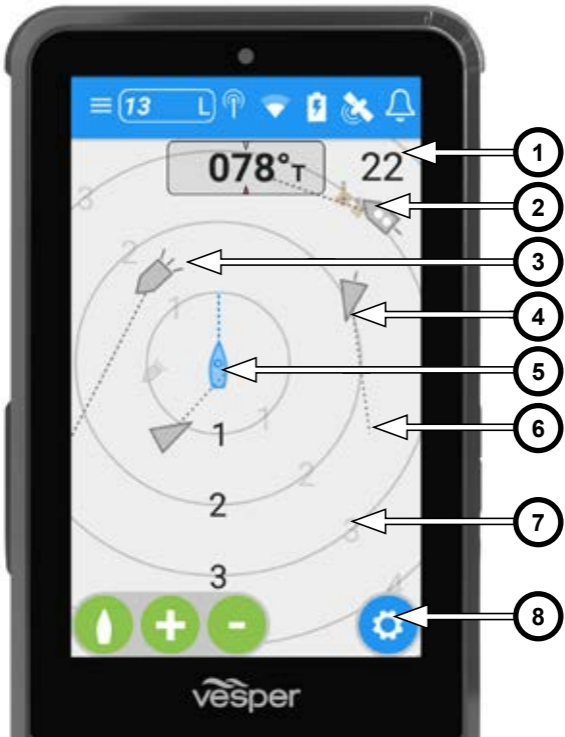



Plotter with Target selected

A target with the highest risk of collision is highlighted in red. Select this target to display details (14) of name, range and bearing.

9 Heading

Your vessel's heading. (Heading up orientation)

10 Selected Target (Highlighted with boxed corners)

11 Crossing Situation

12 Range (zoom) IN / OUT

13 Center Boat

14 Selected Target Details

AIS Symbol, Name, Range and Bearing.

15 Target location relevant to your vessel

Displayed by the lower right hand icon.

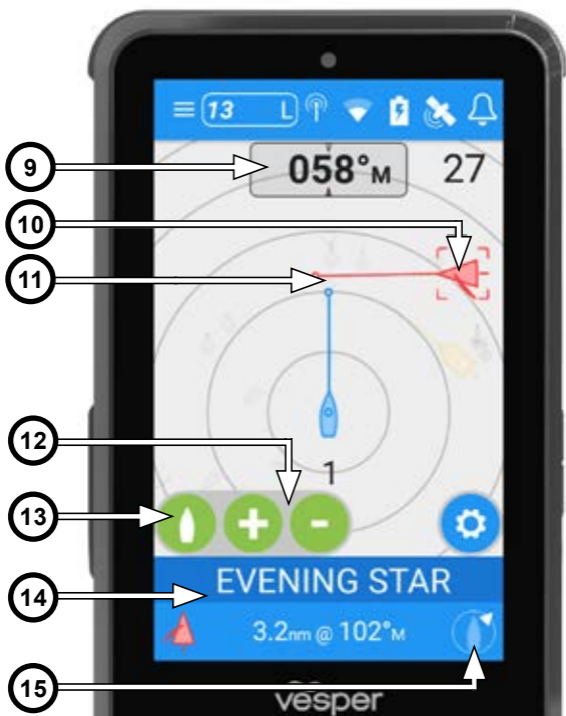



AIS Target Detail View

The AIS Target Detail screen provides all static and dynamic AIS information. Select the following functions:

- 1 Call**
Initiate an individual DSC call
- 2 Find**
Moves to the Plotter screen to locate the target
- 3 Add / Remove**
Add the target to Favorites in the Directory
- 4 Avoid**
Moves to the Collision Avoidance screen





Directory

The Directory screen displays nearby vessels, recent vessels or favorites.

1 Favorites

2 Man Overboard

3 Target Type

4 Target Name

5 Add Vessels to Favorites

Manually enter individual or a group target. View in favorites.

6 Recent

(Calls and alarms from recent targets)

7 Nearby

(Live AIS targets)

8 Target location relative to your vessel





Anchor watch

Select Anchor watch from the Main Menu.

Note - Before you anchor, see SOG (Speed Over Ground) and depth information to determine when it is safe to anchor.

As you drop the vessel's actual anchor, select the Drop or Weigh Anchor icon (5) at the same time to start the Anchor watch monitoring.

Once anchored, you may fine tune the anchor position by using the Anchor Move icon (6).

Change the Alarm Radius (7) or change the display orientation (14) (north-up or heading-up).

If the vessel moves (drags) outside of the Guard Zone radius, the alarm will sound alerting that your anchor is dragging.

Eg: See the position of the vessel (12).

The alarm has sounded, the radius is red indicating the vessel has dragged outside of the set radius.

Select the Drop or Weigh Anchor icon (5) as you weigh anchor to deactivate Anchor watch.



Anchor watch via the Cortex Onboard App

Anchor watch can be accessed and controlled from your phone with the Cortex Onboard App while on board your vessel, or remotely using the Cortex Monitor App.

Cortex Onboard uses WiFi from your M1 hub to connect. Cortex Monitor uses cellular coverage to send information from your M1 hub to your phone.

Anchor Watch is available on a Cortex Monitor Premium Subscription.



Anchor watch

- 1 Anchor Scope**
Current scope, displayed for 30 minutes from anchor drop
- 2 Guard Zone Radius**
- 3 Anchor location**
- 4 Your vessel track markers** (every 15 sec)
- 5 Drop or Weigh Anchor**
- 6 Anchor Move**
- 7 Change Guard Zone Radius**
- 8 Depth**
(via NMEA input)
- 9 Heading**
- 10 Guard Zone**
- 11 Equivalent Scope**
For current guard radius
- 12 Your vessel**
- 13 Range and Bearing to Anchor**
- 14 Change anchor orientation**

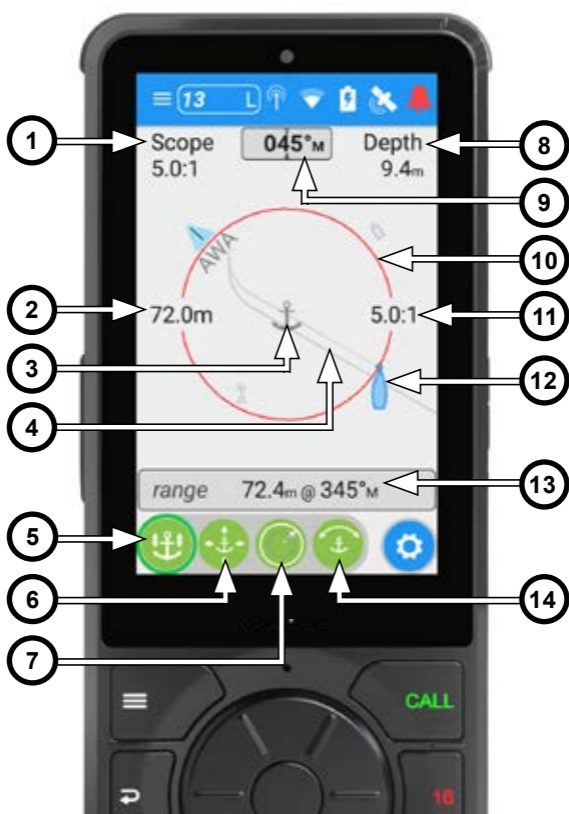



Collision avoidance

When a target is a potential collision risk, Cortex sounds an alarm and a notification pops up on the screen.

The collision alarm escalates until acknowledged

Selecting the alarm opens the Collision avoidance screen and acknowledges the alarm. The vessel icon will change from Red to Grey when the target is no longer a risk.

You can also navigate to the Collision avoidance screen from the Main Menu or from the AIS Target Detail View.

View the target vessel's navigation light sectors (9) to help determine if it is a cross or overtaking situation, and who has the right of way. Vector Lines (3) project the relative direction the target vessel. CPA (Closest Point of Approach) and TCPA (Time to Closest Point of Approach) (11) indicate when and at what distance you will be closest to the target vessel at current course and speed.

Selecting CALL TARGET (7) to make an individual DSC call to that vessel.

The DSC screen will pre-populate the vessel, channel and call type. From this screen you can initiate a DSC call, add them to your Favorites or return to the Collision avoidance screen.

Selecting Vessel Details (5) displays all vessel details.

Trial Maneuver Tool

Selecting Trial Maneuver (6) allows you to simulate the effect of adjusting your course using the Trial Maneuver Slider (10).

Suggested course corrections are displayed in the top right hand side (8).

Note - Observe how the vector to the target will change color from red (collision risk) to grey (all clear) as you simulate course changes.

Note - Good seamanship, awareness of the position and movement of surrounding vessels and objects and COLREG right of way rules always apply before making course corrections.



Collision avoidance

- | | |
|-------------------------|---|
| 1 Current VHF channel* | 7 Call selected vessel |
| 2 Name of target vessel | 8 Suggested correction |
| 3 Crossing situation | 9 Selected target |
| 4 Range ring | 10 Trial maneuver slider |
| 5 Vessel details | 11 Crossing situation |
| 6 Trial Maneuver Slider | Range with current distance and bearing. Passing with CPA and TCPA. |

*Note - Use the Click-wheel to change VHF channel.
Use PTT to make the call.
(No need to navigate back to the VHF screen).





Man Overboard



If a person falls overboard, press the Man Overboard (MOB) key on the handset to instantly drop a waypoint (Red flag icon) (3) to mark the current position of your vessel.



Similarly, if an AIS MOB beacon is detected the handset's MOB alarm will sound and the beacon will be marked by a red circle with an X. (4)



An MOB alarm is repeated every 30 seconds until the alarm is acknowledged or canceled.

An MOB data bar providing Name, Range and Bearing to the MOB since the MOB was initiated, is displayed along the bottom of the screen. (12)

The MOB data bar persists across all pages and remains visible until the MOB alarm is canceled.

The track back will automatically treat the MOB target (4) position with a higher priority than the MOB waypoint.(3)

Note - (7) The MOB alarm does NOT initiate a DSC call automatically.

Note - the DSC distress button must always be used to send the distress call.



Man Overboard

- 1 **Current VHF Channel**
- 2 **Your Vessel Heading**
- 3 **MOB key waypoint**
- 4 **MOB Target**
- 5 **Range Ring**
- 6 **Clear MOB waypoint**
Only clears waypoint(s) set with the MOB button.
- 7 **AIS MOB device data**
Waypoint details, time in water, GPS position.
- 8 **Initiate MOB DSC Call**
- 9 **Water Temperature**
via NMEA input
- 10 **Suggested steering**
to retrieve MOB
- 11 **Your Vessel**
- 12 **MOB Data bar**
Name, Range, Bearing



Copyright © 2020, Vesper Marine Ltd.

Vesper Marine, Vesper, Cortex, VHF Reimagined, WatchMate, AIS WatchMate, WatchMate Vision, deckWatch, smartAIS and Always On Always Visible Always Watching are trademarks or registered trademarks of Vesper Marine Ltd.

All other products are trademarks or registered trademarks of their respective owners.

Unless otherwise indicated, all documentation and operating software contained within this product or distributed with this product is copyrighted by Vesper Marine Ltd. All rights are reserved.

Portions of this product may use software licensed under open source license agreements. Source code for the applicable software is available upon request from Vesper Marine Ltd.



45 Sale Street, Freemans Bay,
Auckland, New Zealand.
Phone +64 9 950 4848

info@vespermarine.com www.vespermarine.com

www.facebook.com/vespermarine