

CHX Bezel Removal Instructions Single and Twin Top Mount Controls

Separating a Bezel Cover from a Bezel Base in a Mounted Configuration

1. Side view of the control
assembly

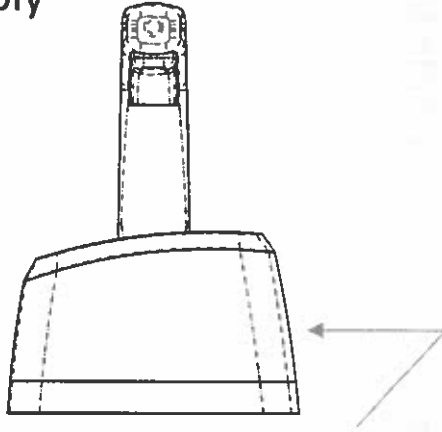

Apply force to the forward face of
the bezel until Tab 1 disengages

2. Side view of the control
assembly

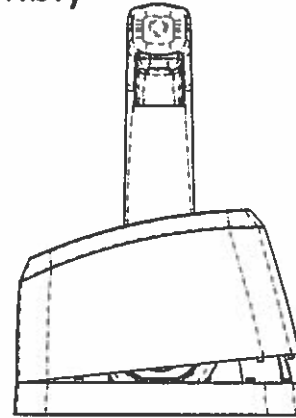

The forward portion of the bezel
will tilt up

3. Side view of the control
assembly

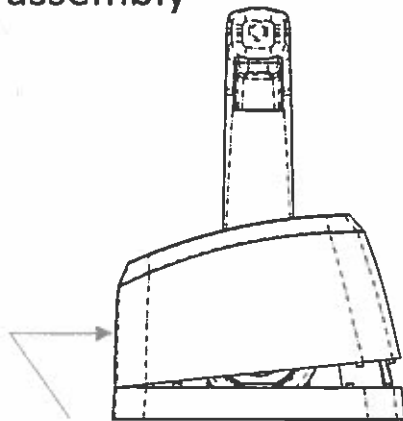

Apply force to the rearward face of
the bezel until Tab 2 disengages

4. Side view of the control
assembly

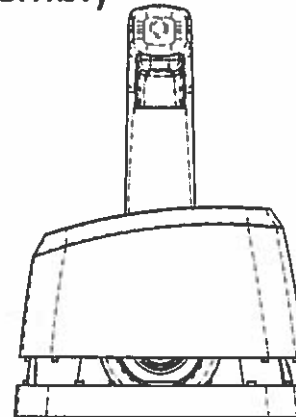

The bezel cover will then separate
from the bezel base

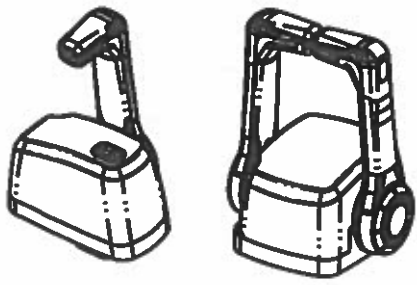

CHX Mounting Template

Single & Twin Top Mount Controls

Panel Cut Out (Full Size)

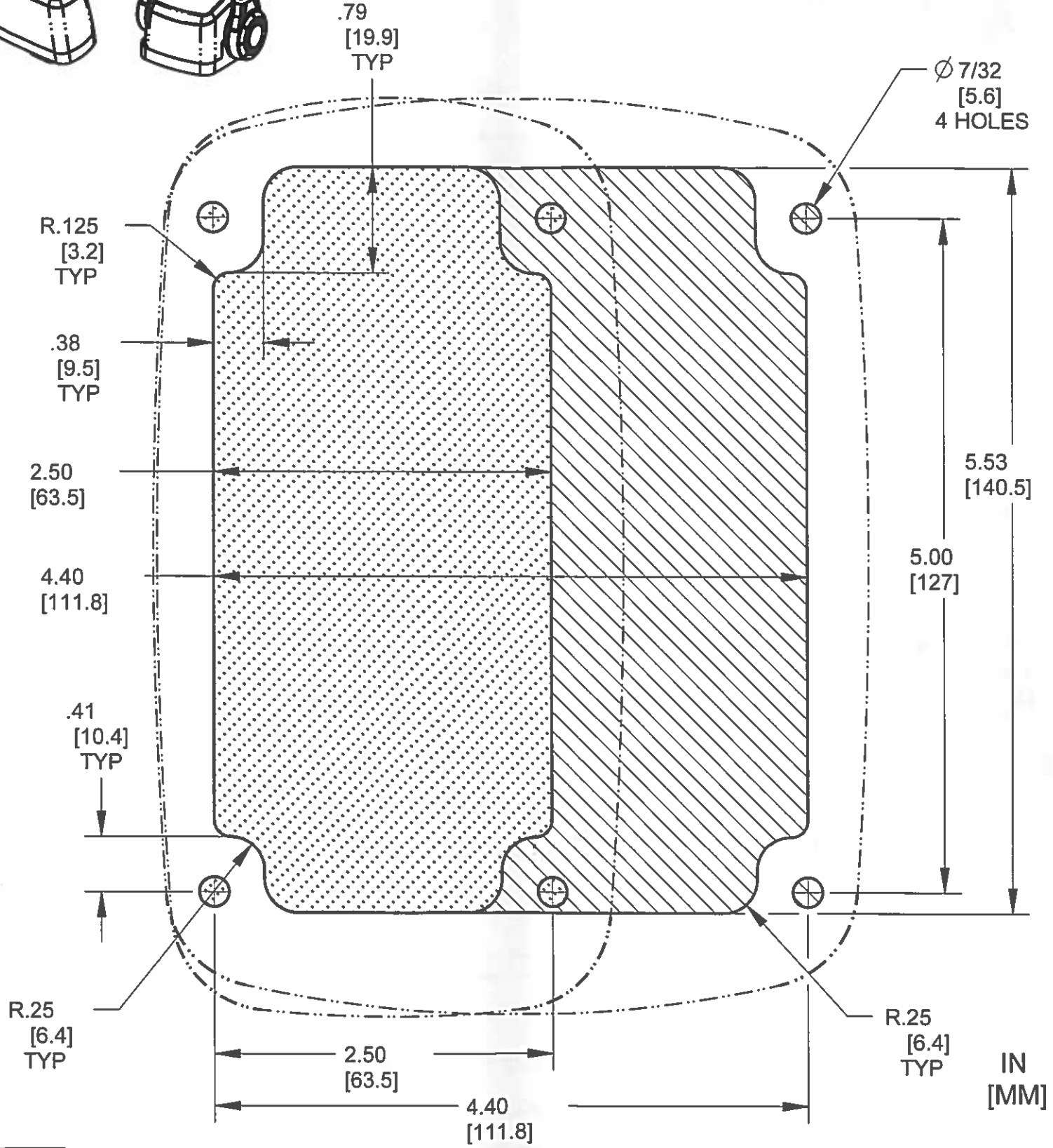

REMOVE ENTIRE HATCHED AREA WHEN MOUNTING BOTH SINGLE & TWIN CONTROLS ON TOP OF PANEL.



REMOVE THIS AREA WHEN MOUNTING TWIN CONTROL ON TOP OF PANEL.

Please Note:
 This template has been downloaded electronically or copied from another document, please check all dimensions on the template before cutting anything. Different printers or copiers may scale differently. This template is included in all mounting kits.

CHX Power Trim and Tilt Wire Diagram Twin Top Mount Controls

